



<input type="checkbox"/> QUOTE FORM PLEASE CHECK BOX FOR QUOTE ONLY	<input type="checkbox"/> ORDER FORM PLEASE CHECK BOX TO PROCESS THIS ORDER
---	--

Order Date _____

COMPANY NAME _____ SALESPERSON _____ PO/SIDEMARK _____ RMM Date _____

ADDRESS _____ CONTACT _____ JOB NUMBER _____ RMI Date _____

SUBDIVISION _____ PHONE _____

CHECK MARK EACH FOR EACH POLISHED EDGE OF EACH PANEL

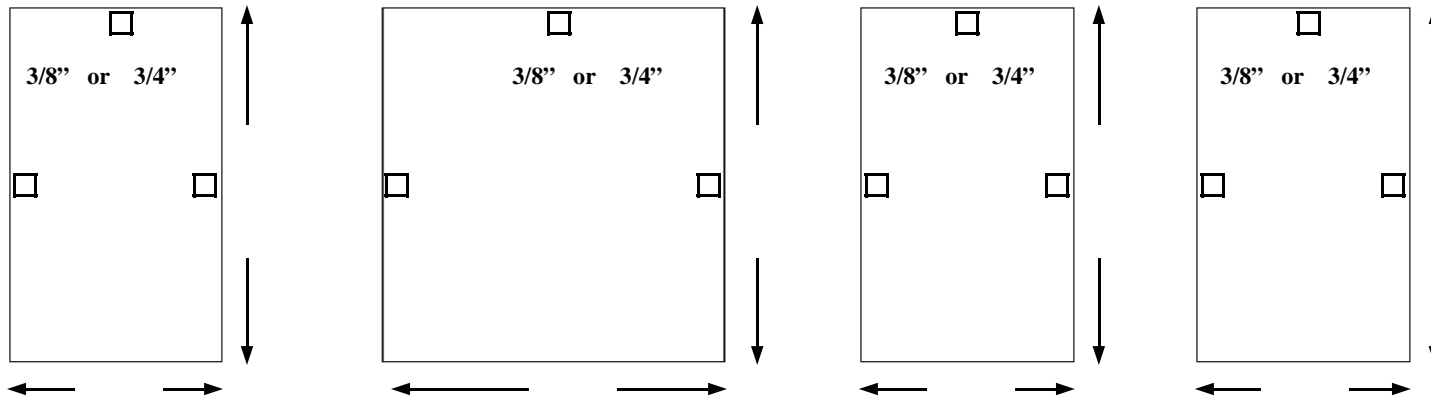

FINISH

MATTE

GLOSS

Color :

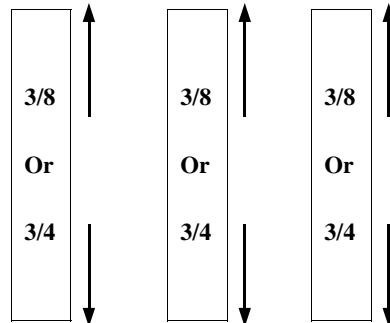
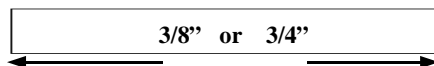
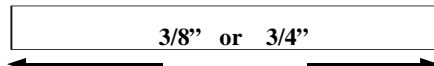
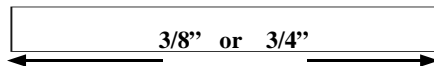

Notes :

- Qty
- ___ Soap Insert
 - ___ Shampoo Insert
 - ___ Corner Combo Shelf Unit
 - ___ Corner Shower Seat

- Qty
- ___ Inside Corner Trim
 - ___ Edge Trim
 - ___ Outside Corner Trim

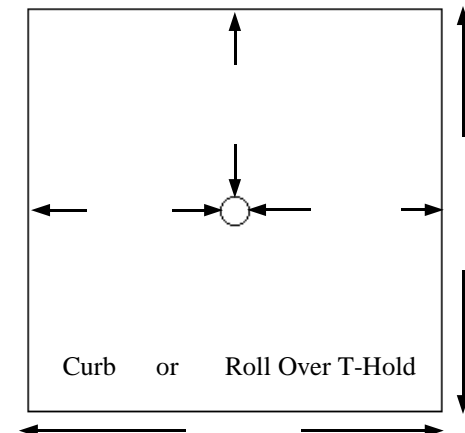

Special Instructions:	Box/Carton: YES / NO
-----------------------	----------------------

CUSTOM SHOWER BASE



R
O
M
A
N

M
A
R
B
L
E

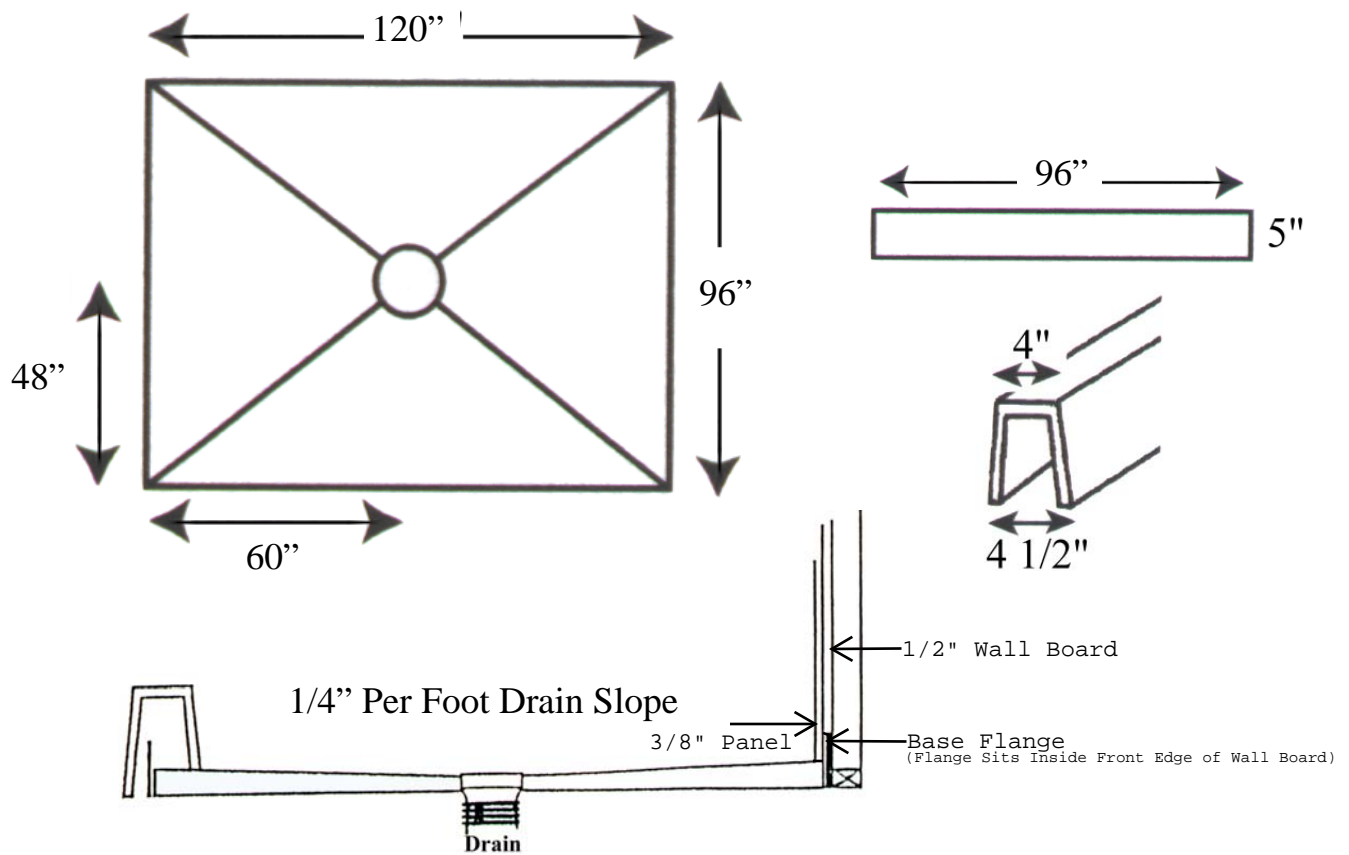
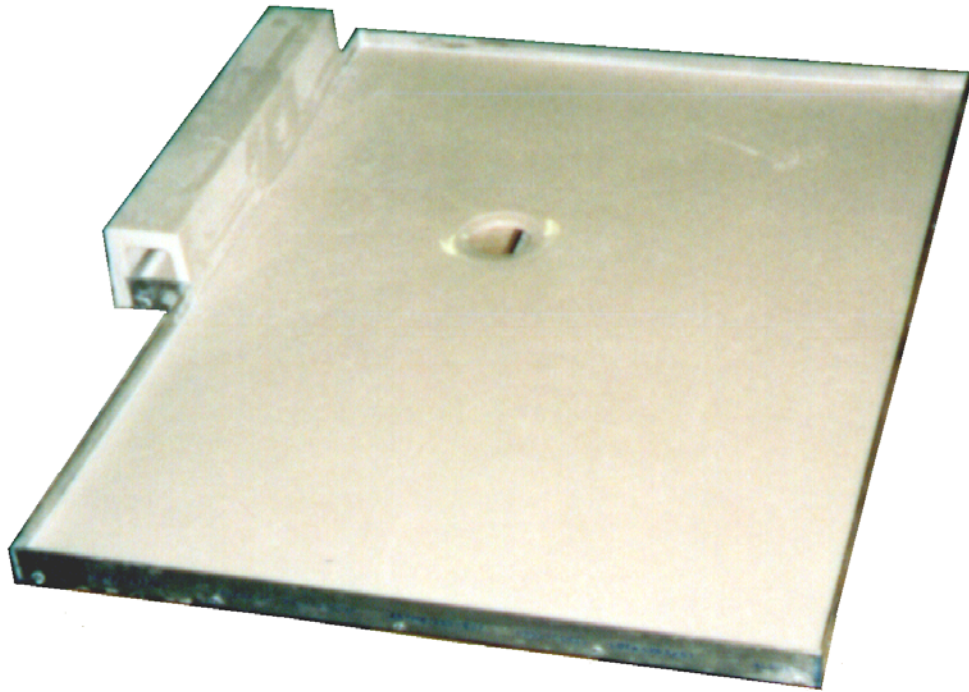

1 3/8" Outside Edge to 1/2" Thickness at Drain
With no front threshold, this unit is ideal for handicap applications.

BATHROOM ACCESSORIES



SOAP & SHAMPOO INSERTS

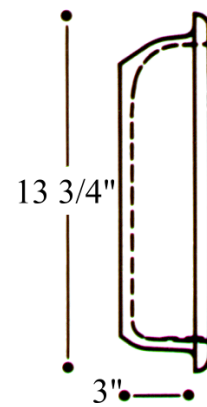
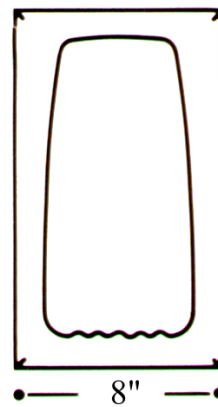
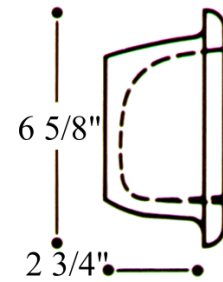
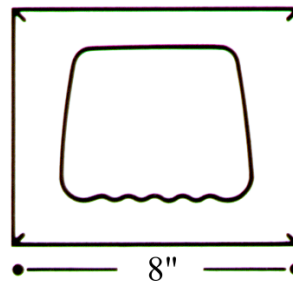
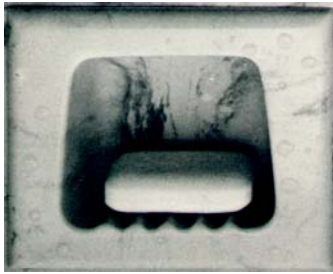

R
O
M
A
N

M
A
R
B
L
E

Inserts Require Hole Cut-outs in Panels.

CORNER SHELF UNIT

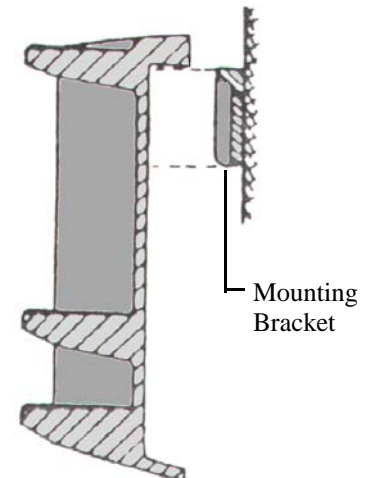
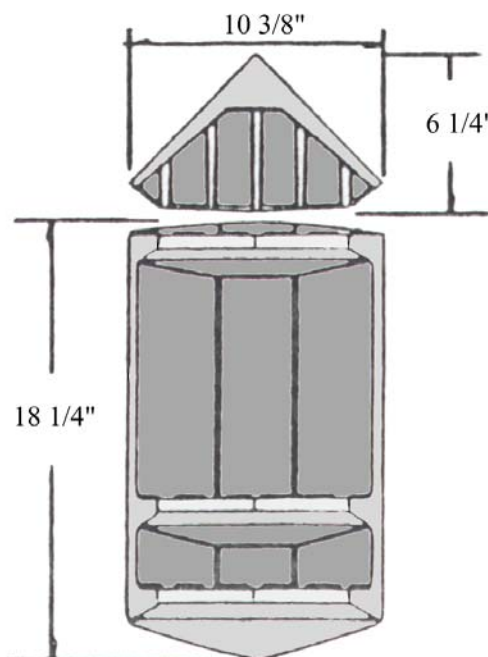
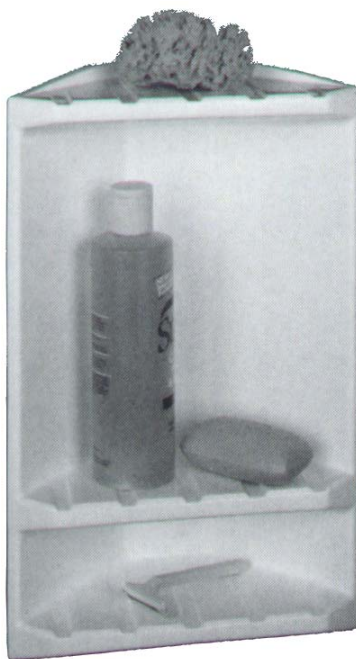

*This unit is a post panel installation.
Does Not Require Hole Cut-outs in Panels.*

CORNER SHOWER SEAT



R
O
M
A
N

M
A
R
B
L
E

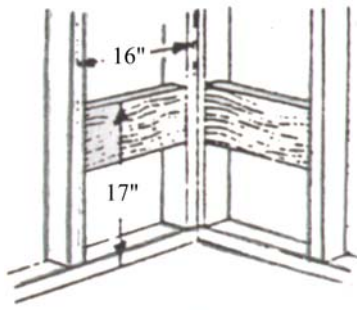
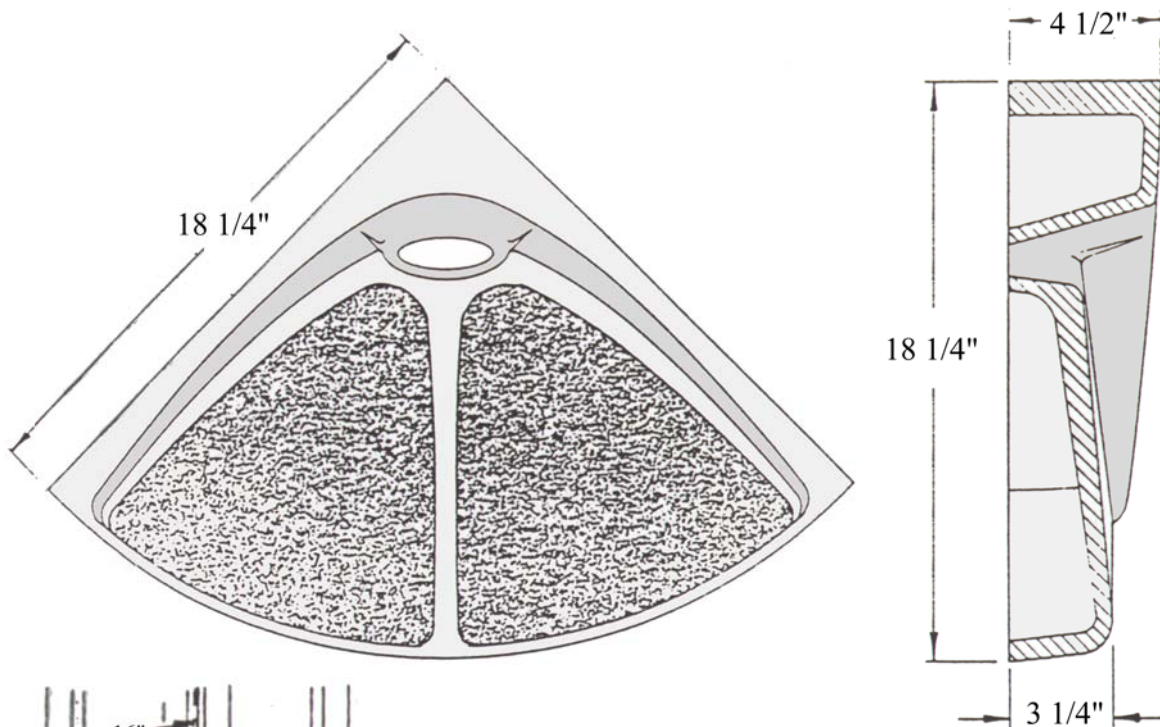

#1 - SITE PREPARATION: 1" x 8" Backing boards are nailed in position between studs as shown. If access can be gained to the rear side of the backing boards, plan seat installation using stainless steel bolts and washers. Wall anchors or lag screws may be used in inaccessible situations. Steel based hardware will need to be rust proofed.

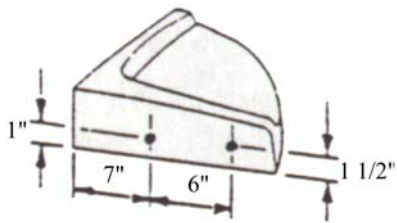

#2 - Drill holes through each vertical mounting face of the seat in locations as shown. Hole size will be dependent on choice of mounting hardware.

#3 - Fabricate an installation support from 3/4" plywood or particle board to dimensions shown.

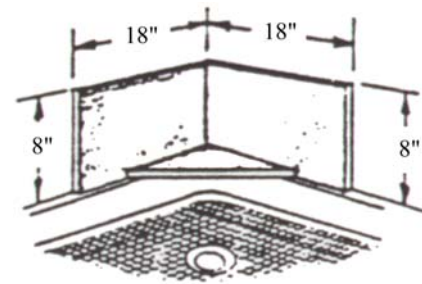

#4 - Place the support on top of the shower pan curb and push it into the corner. Locate the seat on top of the support. Mark holes in seat as guides. Remove seat and drill holes in wall paneling. Wipe down wall and seat surfaces and locate seat as before. Secure the seat with mounting hardware. Remove support and apply silicone sealant along junction of seat and walls. Allow 24 hours curing time before actual use.

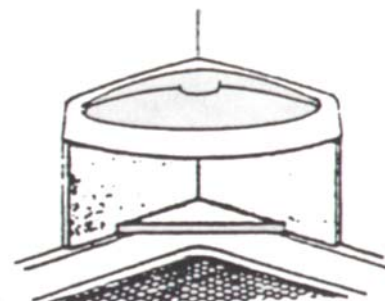

NOTE: BEFORE DRILLING HOLES IN WALL STRUCTURE, VERIFY THAT THERE ARE NO WATER PIPES OR ELECTRICAL WIRING CONCEALED BEHIND HOLE

TRIM PIECES



R
O
M
A
N

M
A
R
B
L
E



INSIDE CORNER

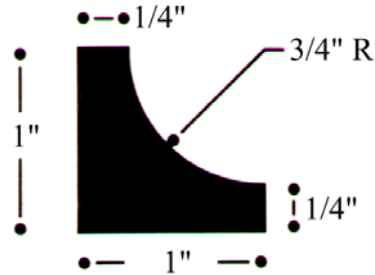

CAP TRIM

Available in 100" Lengths

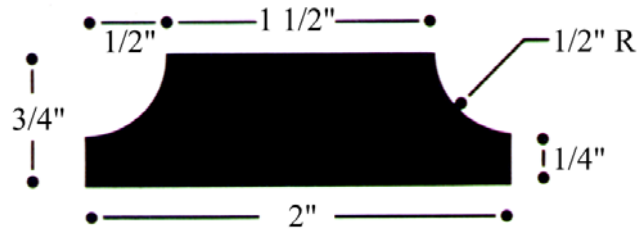

EDGE TRIM

Available in 100" Lengths

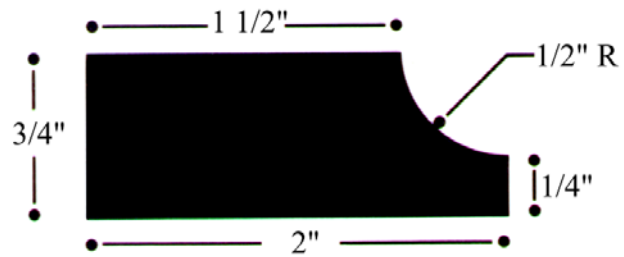

DOOR THRESHOLD

Available in 48" Lengths

